

# VORTEX FLOW METER CATALOG





## Introduction

Vortex Flowmeter works on the Karman vortex principle that swirls generated by a bluff body in the pipe. The number of swirls are proportional to the volumetric flow in the pipe. Vortex flowmeter widely used for gases, steam and liquid applications. It is ideal for measuring saturated and superheated steam in large facilities to improve steam production efficiency.



## Principle

When the fluid in the pipeline passes the burble generator(triangular prism),burble will generate due to the acceleration of partial flow rate. The burble will arise alternatively in two burble lines, which is called Karman vortex.

The releasing frequency of Karman vortex depends on the size of triangle prim and flow rate of fluid, while independent of the medium feature parameter, such as the temperature, pressure, it can be indicated by the following formulas:

$F = sR \cdot v (1 - 1.27 \cdot d/D)$	$Q = 3600 \cdot F/K$	$M = Q \cdot P$
F	The releasing frequency of Karman vortex (Hz)	
Sr	Strouhal number (unit: dimensionless)	
V	Medium flow rate (m/s)	
d	The width of triangle prim	
D	Vortex meter inner diameter (m)	
Q	Instantaneous volume flow rate (m <sup>3</sup> /h)	
K	Vortex meter coefficient (unit pulse number/m <sup>3</sup> )	
M	Instantaneous quality flow rate (kg/h)	
P	Fluid density (kg/m <sup>3</sup> )	

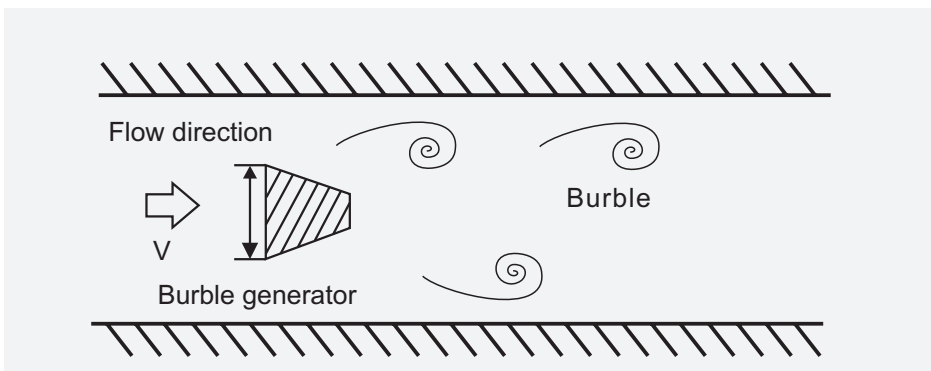



## Application

Applications in the chemicals and petrochemicals industries, for example, in power generation and heat-supply systems involve widely differing fluids: saturated steam, superheated steam, compressed air, nitrogen, liquefied gases, flue gases, carbon dioxide, fully demineralized water, solvents, heat-transfer oils, boiler feedwater, condensate, etc.



## Features

- Integrated pressure and temperature compensation
- 4-20mA, pulse with HART or pulse with RS485 are selectable
- Wide temperature range up to highest temperature 350°C
- Adopt Japan OVAL technology and design
- Embedded sensor, 4 piezo-electric crystal encapsulated inside the sensor.
- No moving parts, no abrasion, non-wearing parts inside, fully welded SS304 body (SS316 selectable)



## Structure

### ● Connection Type



● Compact Type and Remote Type

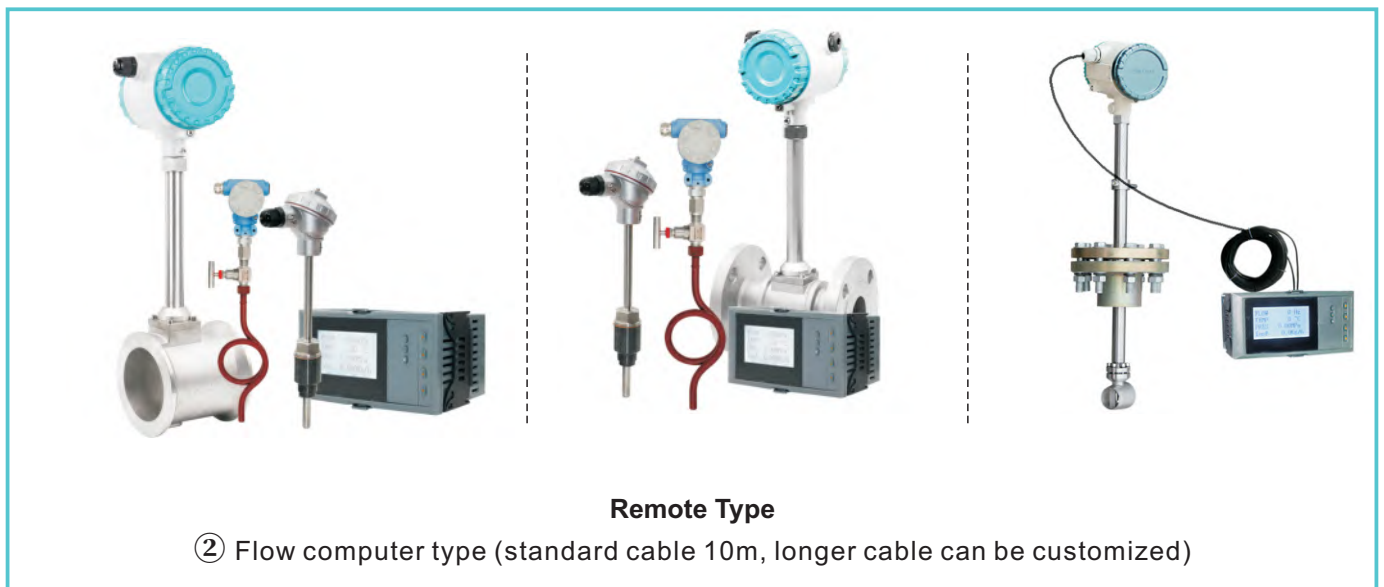
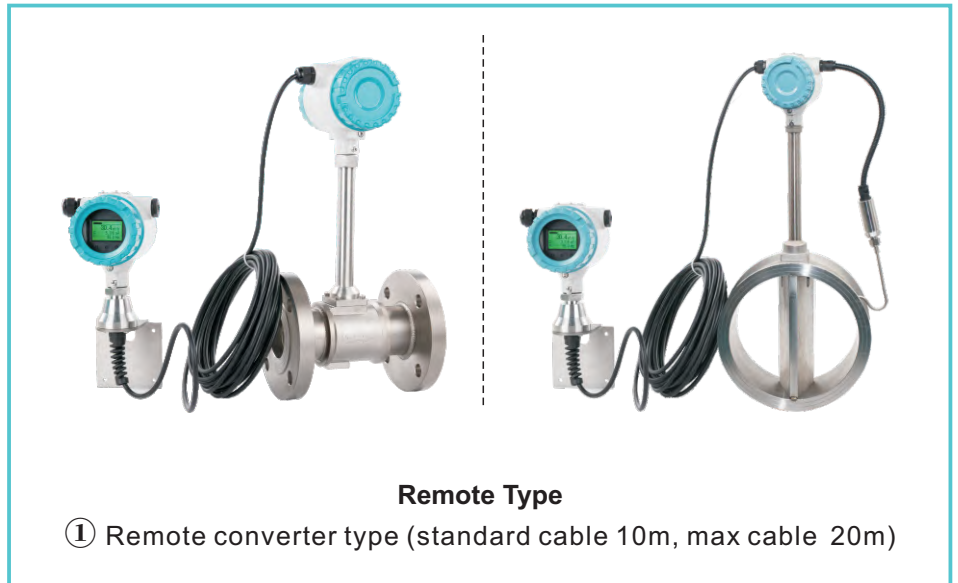



## Parameters

Measured Medium	Liquid, Gas, Steam	
Medium Temp.	-40 ~ + 250°C; -40 ~ + 350°C (high temperature type)	
Pressure	Flange	DIN PN10/PN16/PN25/PN40 JIS10K/20K/30K/40K ANSI 150#/300#
	Wafer	4.0MPa
	Thread	1.6MPa
	Tri-clamp	1.6MPa
	Insertion	1.6MPa
Accuracy	±1.0% (Flange/Wafer/Thread/Tri-clamp) ±1.5% (Insertion type)	
Flow Range	Liquid:0.4-7.0m/s; Gas:4.0-60.0m/s; Steam:5.0-70.0m/s	
Specifications	DN15-DN300 (flange/wafer type) DN80-DN2000 (insertion type) DN15-DN100 (thread/sanitary type)	
Body Material	SS304 (standard) SS316 (optional)	
Reynolds Number	Normal $2 \times 10^4 \sim 7 \times 10^6$	
Resistance Coefficient	$C_d \leq 2.6$	
Vibration Acceleration Allowed	$\leq 0.2g$	
IEP ATEX	IIG Exia IICT5 Ga	
Ambient Condition	Ambient Temp.	-40°C~65°C (Non ex-proof site) -20°C~55°C (Ex-proof site)
	Relative Humidity	$\leq 85\%$
	Pressure	86-106kPa
Power Supply	DC12-30V or 3.6V lithium battery powered	
Signal Output	4-20mA, Pulse	
Communication	RS485 Modbus or HART	



## Flow Range

Table 1 Liquid and Air Flow Range Table (m<sup>3</sup>/h)

Nominal DN(mm)	Liquid (m <sup>3</sup> /h)		Air (m <sup>3</sup> /h)	
	Standard Range	Extended Range	Standard Range	Extended Range
15	0.8-6	0.5-8	6-40	5-50
20	1-8	0.5-12	8-50	6-60
25	1.5-12	0.8-16	10-80	8-120
32	2-20	1.5-25	15-150	10-200
40	2.5-30	2-40	25-200	20-300
50	3-50	2.5-60	30-300	25-500
65	5-80	4-100	50-500	40-800
80	8-120	6-160	80-800	60-1200
100	12-200	8-250	120-1200	100-2000
125	20-300	12-400	160-1600	150-3000
150	30-400	18-600	250-2500	200-4000
200	50-800	30-1200	400-4000	350-8000
250	80-1200	40-1600	600-6000	500-12000
300	100-1600	60-2500	1000-10000	600-16000
400	200-3000	120-5000	1600-16000	1000-25000
500	300-5000	200-8000	2500-25000	1600-40000
600	500-8000	300-10000	4000-40000	2500-60000

Table 2 Saturated Steam Mass Flow Range Table (kg/h)

Absolute Pressure (MPa)		0.2	0.3	0.4	0.5	0.6	0.7	0.8
Temperature (°C)		120.2	133.5	143.62	151.84	158.94	164.96	170.41
Density (kg/m <sup>3</sup> )		1.129	1.651	2.163	2.669	3.17	3.667	4.162
DN15	Qmin	5.645	8.255	10.815	13.345	15.85	18.335	20.81
	Qmax	56.45	82.55	108.15	133.45	158.5	183.35	208.1
DN20	Qmin	6.774	9.906	12.978	16.014	19.02	22.002	24.972
	Qmax	67.74	99.06	129.78	160.14	190.2	220.02	249.72
DN25	Qmin	9.032	13.208	17.304	21.352	25.36	29.336	33.296
	Qmax	135.48	198.12	259.56	320.28	380.4	440.04	499.44
DN32	Qmin	20.322	29.718	38.934	48.042	57.06	66.006	74.916
	Qmax	203.22	297.18	389.34	480.42	570.6	660.06	749.16
DN40	Qmin	22.58	33.02	43.26	53.38	63.4	73.34	83.24
	Qmax	338.7	495.3	648.9	800.7	951	1100.1	1248.6
DN50	Qmin	28.225	41.275	54.075	66.725	79.25	91.675	104.05
	Qmax	564.5	825.5	1081.5	1334.5	1585	1833.5	2081
DN65	Qmin	45.16	66.04	86.52	106.76	126.8	146.68	166.48
	Qmax	903.2	1320.8	1730.4	2135.2	2536	2933.6	3329.6
DN80	Qmin	67.74	99.06	129.78	160.14	190.2	220.02	249.72
	Qmax	1354.8	1981.2	2595.6	3202.8	3804	4400.4	4994.4
DN100	Qmin	112.9	165.1	216.3	266.9	317	366.7	416.2
	Qmax	2258	3302	4326	5338	6340	7334	8324
DN125	Qmin	169.35	247.65	324.45	400.35	475.5	550.05	624.3
	Qmax	3387	4953	6489	8007	9510	11001	12486
DN150	Qmin	225.8	330.2	432.6	533.8	634	733.4	832.4
	Qmax	4516	6604	8652	10676	12680	14668	16648
DN200	Qmin	395.15	577.85	757.05	934.15	1109.5	1283.45	1456.7
	Qmax	9032	13208	17304	21352	25360	29336	33296
DN250	Qmin	564.5	825.5	1081.5	1334.5	1585	1833.5	2081
	Qmax	13548	19812	25956	32028	38040	44004	49944
DN300	Qmin	677.4	990.6	1297.8	1601.4	1902	2200.2	2497.2
	Qmax	18064	26416	34608	42704	50720	58672	66592

Table 2 Saturated Steam Mass Flow Range Table (kg/h)

Absolute Pressure (MPa)		0.9	1.0	1.2	1.4	1.6	1.8	2.0
Temperature (°C)		175.36	179.68	187.96	195.04	201.37	207.11	212.37
Density (kg/m <sup>3</sup> )		4.665	5.147	6.127	7.106	8.085	9.065	10.05
DN15	Qmin	23.325	25.735	30.635	35.53	440.425	45.325	50.25
	Qmax	233.25	257.35	306.35	355.3	404.25	453.25	502.5
DN20	Qmin	27.99	30.882	36.762	42.636	48.51	54.39	60.3
	Qmax	279.9	308.82	367.62	426.36	485.1	543.9	603
DN25	Qmin	37.32	41.176	49.016	56.848	64.68	72.52	80.4
	Qmax	559.8	617.64	735.24	852.72	970.2	1087.8	1206
DN32	Qmin	83.97	92.646	110.286	127.908	145.53	163.17	180.9
	Qmax	839.7	926.46	1102.86	1279.08	1455.3	1631.7	1809
DN40	Qmin	93.3	102.94	122.54	142.12	161.7	181.3	201
	Qmax	1399.5	1544.1	1838.1	2131.8	2425.5	2719.5	3015
DN50	Qmin	116.625	128.675	153.175	177.65	202.125	226.625	251.25
	Qmax	2332.5	2573.5	3063.5	3553	4042.5	4532.5	5025
DN65	Qmin	186.6	205.88	245.08	284.24	323.4	362.6	402
	Qmax	3732	4117.6	4901.6	5684.8	6468	7252	8040
DN80	Qmin	279.9	308.82	367.62	426.36	485.1	543.9	603
	Qmax	5598	6176.4	7352.4	8527.2	9702	10878	12060
DN100	Qmin	466.5	514.7	612.7	710.6	808.5	906.5	1005
	Qmax	9330	10294	12254	14212	16170	18130	20100
DN125	Qmin	699.75	772.05	919.05	1065.9	1212.75	1359.75	1507.5
	Qmax	13995	15441	18381	21318	24255	27195	30150
DN150	Qmin	933	1029.4	1225.4	1421.2	1617	1813	2010
	Qmax	18660	20588	24508	28424	32340	36260	40200
DN200	Qmin	1632.75	1801.45	2144.45	2487.1	2829.75	3172.75	3517.5
	Qmax	37320	41176	49016	56848	64680	72520	80400
DN250	Qmin	2332.5	2573.5	3063.5	3553	4042.5	4532.5	5025
	Qmax	55980	61764	73524	85272	97020	108780	120600
DN300	Qmin	2799	3088.2	3676.2	4263.6	4851	5439	6030
	Qmax	74640	82352	98032	113696	129360	145040	160800

Table 3 Superheated Steam Density & Relative Temperature and Pressure (Kg/m<sup>3</sup>)

Absolute Pressure (MPa)	Temperature ( °C )					
	150	200	250	300	350	400
0.1	0.52	0.46	0.42	0.38		
0.15	0.78	0.70	0.62	0.57	0.52	0.49
0.2	1.04	0.93	0.83	0.76	0.69	0.65
0.25	1.31	1.16	1.04	0.95	0.87	0.81
0.33	1.58	1.39	1.25	1.14	1.05	0.97
0.35	1.85	1.63	1.46	1.33	1.22	1.13
0.4	2.12	1.87	1.68	1.52	1.40	1.29
0.5	-	2.35	2.11	1.91	1.75	1.62
0.6	-	2.84	2.54	2.30	2.11	1.95
0.7	-	3.33	2.97	2.69	2.46	2.27
0.8	-	3.83	3.41	3.08	2.82	2.60
1.0	-	4.86	4.30	3.88	3.54	3.26
1.2	-	5.91	5.20	4.67	4.26	3.92
1.5	-	7.55	6.58	5.89	5.36	4.93
2.0	-	-	8.968	7.97	7.21	6.62
2.5	-	-	11.5	10.1	9.11	8.33
3.0	-	-	14.2	12.3	11.1	10.1
3.5	-	-	17.0	14.6	13.0	11.8
4.0	-	-	-	17.0	15.1	13.6



## Dimension

- Flange Connection Type (DIN PN16 as reference)

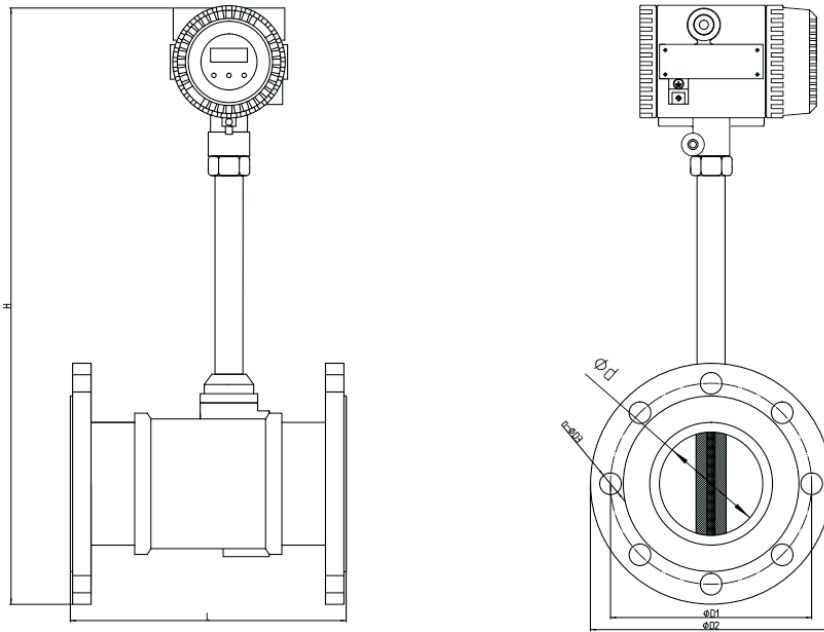

DIN PN16 Flange Connection Dimension

Size	L	H	d	D1	D2	n-D3
DN15	170	440	15	65	95	4-φ14
DN20	170	445	20	75	105	4-φ14
DN25	170	450	26	85	115	4-φ14
DN32	170	462	32	100	140	4-φ18
DN40	190	465	38	110	150	4-φ18
DN50	190	473	48	125	165	4-φ18
DN65	220	487	62	145	185	4-φ18
DN80	220	500	73	160	200	8-φ18
DN100	240	533	95	180	220	8-φ18
DN125	260	560	118	210	250	8-φ18
DN150	280	608	140	240	285	8-φ22
DN200	300	640	200	295	340	12-φ22
DN250	360	705	250	355	405	12-φ26
DN300	400	752	300	410	460	12-φ26

Noted: Above dimension as per flange DIN PN16.



## Dimension

- Wafer Connection Type

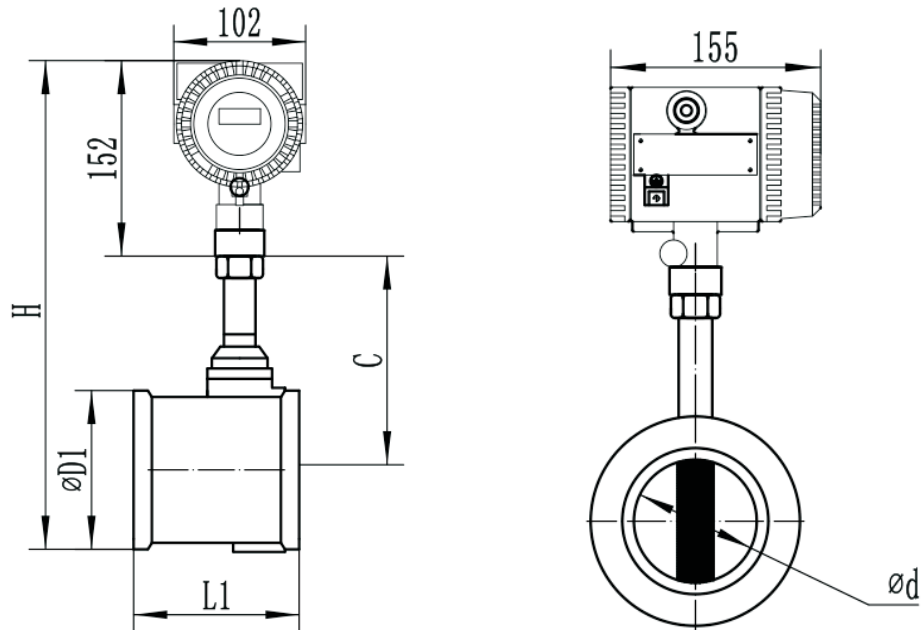

Size	L1	D1	d	C
DN15	65	65	15	240.5
DN20	65	65	20	240.5
DN25	65	65	26	240.5
DN32	65	65	32	240.5
DN40	80	76	38	237
DN50	80	88	48	237
DN65	92	101	62	242.5
DN80	100	112	73	247
DN100	124	134	95	271
DN125	145	158	118	284
DN150	165	180	140	313
DN200	195	247	200	319.5
DN250	115	300	250	348
DN300	130	347	300	369.5



### Insertion Type

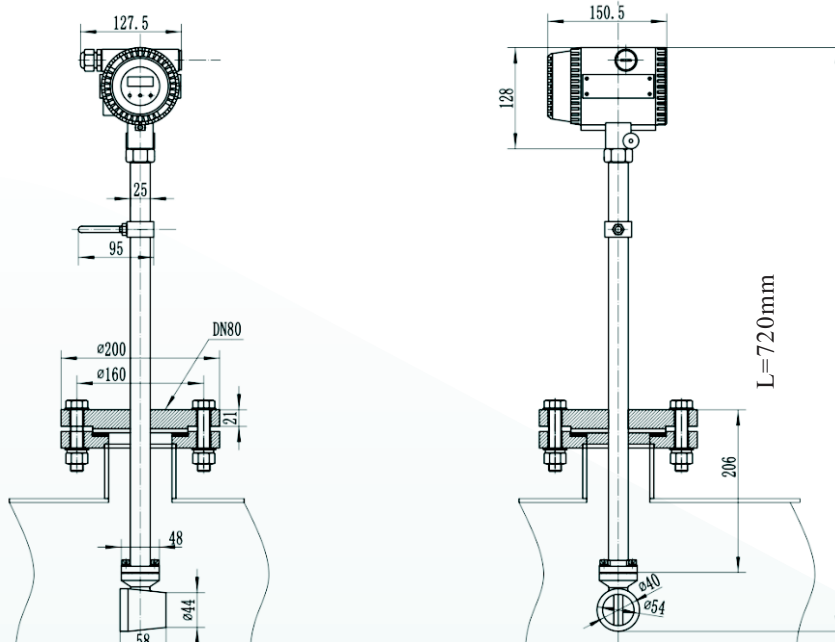



## Vortex Flow Meter Installation

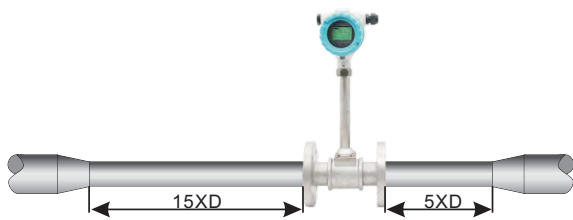

Concentric Reducers Pipeline

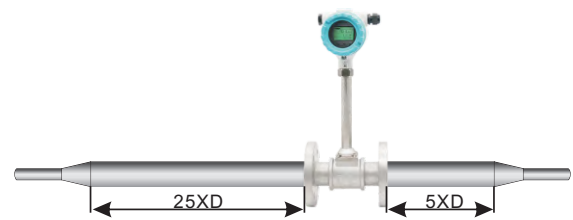

Concentric Expansion Pipeline

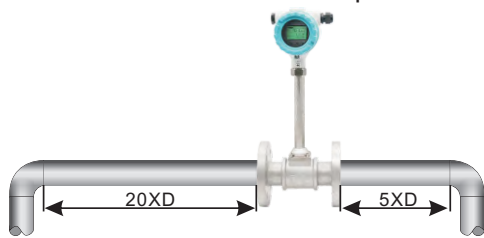

Single Square Bend

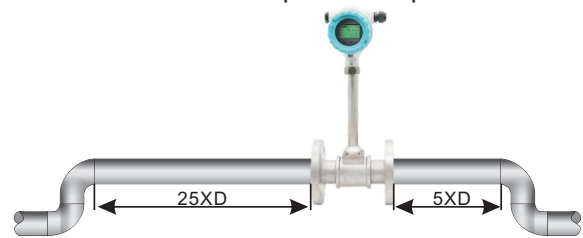

Two Square Bends At Same Plane

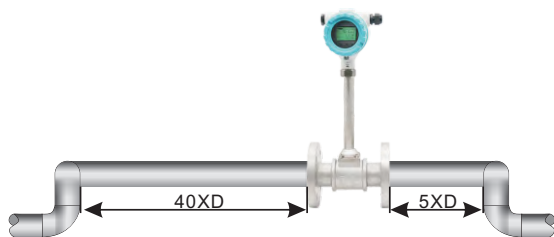

Two Square Bends At Different Plane

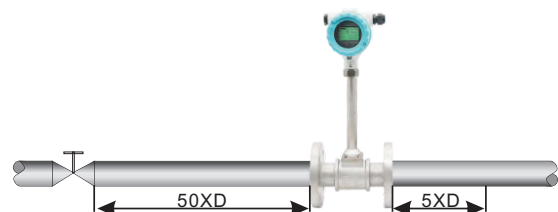

Regulating Valve, Half-open Gate Valve